



3Shape CAMbridge

Fully automated manufacturing by automatic preparation of the completed design

3Shape CAMbridge™

NEW

Be more competitive with fully automated manufacturing

The 3Shape CAMbridge™ enables fully automated manufacturing by automatic preparation of the completed design such as addition of sprues, drops and optimal placement in the blank for milling.

3Shape CAMbridge™ provides **fully automated preparation of 3D files** for output on RP machines and milling machines. The software is optimized for mass production within mass customization businesses, like hearing instruments or dental restorations.

The **user-friendly interface, combined with the highest level of automation** available, empowers non-technical operators to run a streamlined production. As files are added to the job, 3Shape CAMbridge™ automatically begins processing in the background. The software utilizes multicore processors to speed up the calculations. Finalizing the job is just a matter of clicking the 'Produce' button.

Mass production within mass customization

The software offers a high level of customization. Automation is configured using a rich set of rules that is stored as machine settings and styles. These styles can be selected individually per item in the job. As input, 3Shape CAMbridge™ accepts STL, HPS, and DCM files. If you are using 3Shape DentalManager™, you can simply drag and drop order items into 3Shape CAMbridge™.

3Shape CAM software

The CAM software offers very competitive milling strategies for 3.5-axis machining. The software is also able to seamlessly transfer files and control to the machine. Dynamic milling simulation is also included.

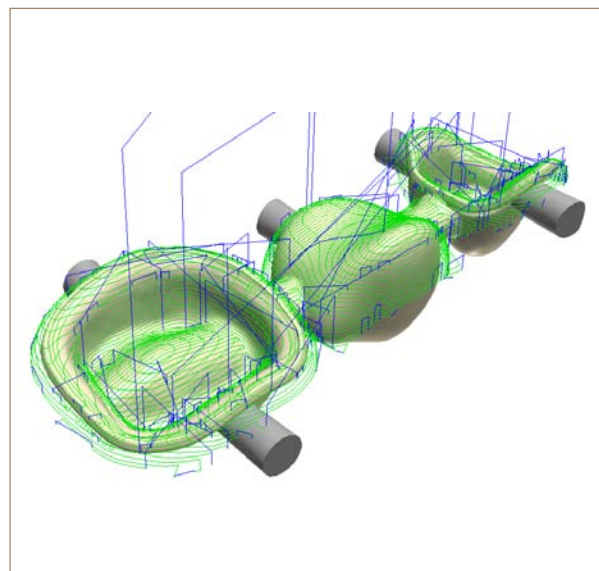
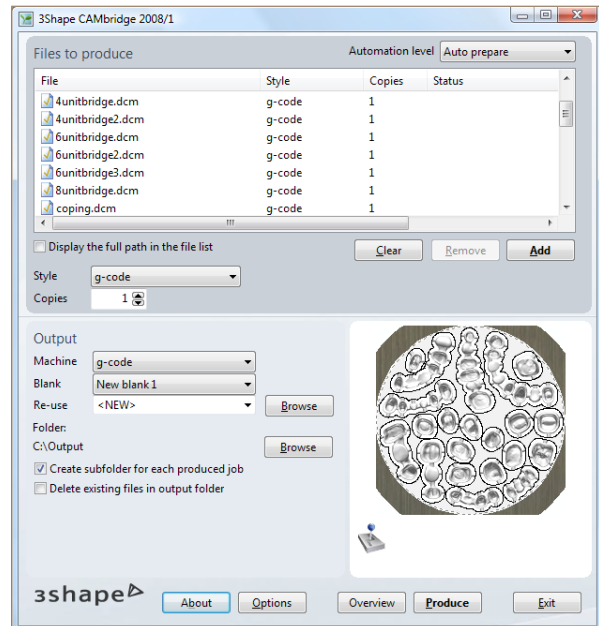

3Shape CAM milling strategy.

Rapid Prototyping machines

3Shape CAMbridge™ supports a wide range of RP machines. The software can automatically perform all steps required for the preparation and for most of the machines seamlessly transfer files and control to the machine software/driver. If your device isn't supported, you can use the general purpose RP machine module which can be customized to fit the specification of your device. The output can be saved as STL, SLI, or CLI files.



Automatic preparation for wax printers.

Milling Machines

Currently 3Shape offers 3.5-axis machining. Alternatively, we also offer seamless transfer of the jobs to the most popular 3rd party CAM solutions in the market. The milling capabilities are optimized for dental restorations. The highest level of automation is achieved when using DCM files from 3Shape DentalDesigner™.

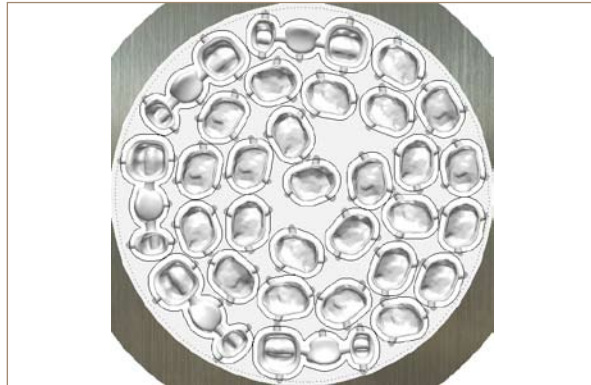

Automatic placement of 51 units in 98mm blank.

Visual Inspection

Although designed for full automation, 3Shape CAMbridge also allows for visual inspection and manual editing of placement (nesting), & item orientation and vertical placement. For RP machines, the supports can be modified and for milling machines both sprues (support pins), drops, and engraving can be modified. Dynamic milling simulation is also included.

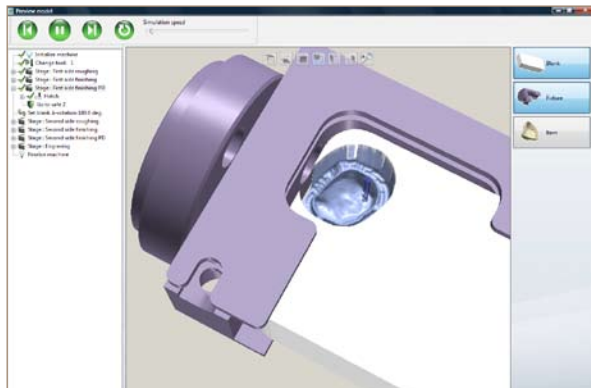

Visual inspection and manual editing.

HIGHLIGHTS

- **Fully automated preparation** - of 3D files for output on RP machines and milling machines
- **Customization** - high level of customization
- **User-friendly interface** - with drag & drop functionality you are only one click from production
- **Re-use of partially manufactured blanks** - ensuring lower manufacturing costs
- **Visual inspection and manual editing** - item orientation and vertical placement

About 3Shape A/S

3Shape A/S is a Danish company specializing in the development and marketing of 3D scanners and CAD/CAM software solutions. These are used for the creation, processing, analysis and management of high-quality 3D data.

Implementing 3Shape's solutions brings **significant benefits in terms of quality, productivity and creativity** to complex manufacturing processes, where the handling of physical objects is critical.

3Shape is a privately-held Danish company, whose headquarters are in Copenhagen, with development teams in Denmark as well as the Ukraine. In early 2009, we opened Sales and Support Offices in New Jersey, USA and Shanghai, China.

For further information on 3Shape A/S and the CAMbridge™ system please visit **www.3Shape.com**.



3Shape A/S
Holmens Kanal 7, 4.
DK-1060 Copenhagen K
Phone +45 70 27 26 20

3Shape Inc.
571 Central Ave., Suite 109
New Providence, New Jersey 07974
Phone: +1 908 219 46 41

3Shape, Asia
Room 1205, No.738 Shangcheng Road
200120 Shanghai
Phone: +86 138 183 38960